

Dynaric, Inc.

NP5000



High Speed Fully Automatic Strapping Machine

Exceeding Demanding
Requirements of the
Newspaper and Graphic
Arts Industry



Capable Throughput of Over 45 Bundles Per Minute



XL Coils

Increase your production further by reducing downtime caused by changing coils. Dynaric's XL coils are still produced using the same high quality materials as our standard coils but with more footage therefore eliminating up to 30% of your coil changes.

Dynaric, Inc.



Phone: (800) 526-0827 Fax: (757) 363-8016 E-mail: order@dynaric.com Web: www.dynaric.com

Certified Minority Owned Business

NP5000



The NP5000 is the latest addition to the Dynaric line of dependable high speed strapping machines with a capable throughput of over 45 bundles per minute.

The NP5000 is equipped with a 5.6" graphic display screen, utilizing touch screen technology, quick change dispenser system, end of strap sensor and an easy strap feeding system, therefore making this strapping machine productive and user friendly. Because of the soft clamp compression bundle conditioning system, extra wide conveyor belts and variable speed conveyor, the NP5000 handles various bundle dimensions with ease.

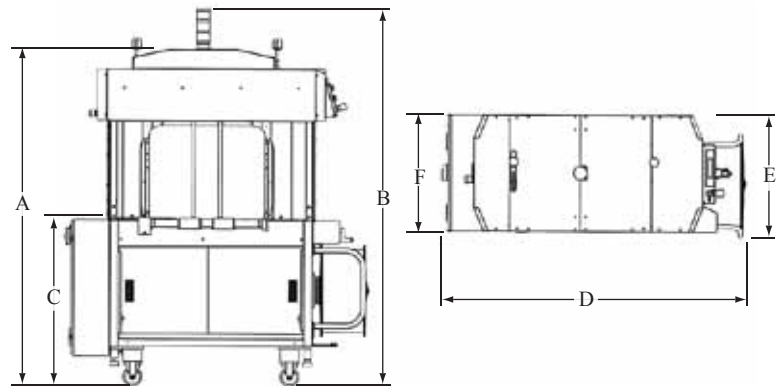

- A. 68.0" (1728.5 mm)
- B. 76.2" (1936.5 mm)
- C. 33.9" (862.5 mm)
- D. 61.6" (1564.5 mm)
- E. 24.7" (627 mm)
- F. 23.6" (599 mm)

At A Glance

- **AC Servo Drive** eliminates clutches and brakes used in welding head control
- **Modern touch screen display** simplifies machine setup and improves operator troubleshooting
- **Automatic strap tensioning** depending on height of bundle improves product consistency
- **Automatic strap loading** and self strap clearing after completion of coil speeds coil changes
- **Operator stations on both sides of machine** simplify operation
- **Bundle stops and side squaring bars** preserve bundle integrity
- **Simplified strap arch with fewer moving parts** improves long term reliability
- **Quick change strap dispenser** with capacity for Extra Length (Dynaric XL) coils extends time between coil changes
- **Soft bundle press** conforms to odd shaped bundles for more consistent tension
- **Variable speed conveyor drive** allows speed matching for better control of incoming bundles

Overall Width:	23.6" (600 mm)
Overall Length:	53.5" (1360 mm)
Overall Height:	71.3"-76.4" (1181-1941 mm)
Conveyor Height:	31.5"-36.6" (800-930 mm)*
Strap Size:	6 mm (5 mm optional)
Speed:	Single strap: 45 Bundles/min. Parallel straps: 21 Bundles/min. 50 Straps/min.
Weight:	1200 lbs (550 kg)
Sealing Method:	Heat Seal
Operation:	Electro-pneumatic
Air Requirements:	22.3 CFM @ 87 PSI
Electrical Requirements:	Approximately 1.5 kW 208V/230V/460V, 3 phase
Bundle Size:	Width: Max. 22" (560 mm) Min. 4.3" (110 mm) Length: Min. 5.5" (140 mm) Height: Max. 15" (380 mm) 18" (457 mm) Optional Min. 0.8" (20 mm) Weight: Max. 55.1 lbs (25 kg)

*Specify with order

