

Dynaric, Inc.

# CP150

## Fully Automatic High Speed Strapping Machine

Designed  
for the  
Graphic  
Arts  
Industry

**BUNDLE  
SPEED  
60**  
PER MIN.



## XL Coils

Increase your production further by reducing downtime caused by changing coils. Dynaric's XL coils are still produced using the same high quality materials as our standard coils but with more footage therefore eliminating up to 30% of your coil changes.

**Dynaric, Inc.**



Certified Minority Owned Company

Phone: (800) 526-0827 | Fax: (757) 363-8016 | E-mail: [order@dynaric.com](mailto:order@dynaric.com) | Web: [www.dynaric.com](http://www.dynaric.com)

# Dynaric, Inc.

## CP150



The CP150 is the machine of choice over all the commercial printing strapping systems on the market today. With a seven point bundle conditioning system the CP150 is designed to stabilize bundles of printed matter, particularly hard to handle magazines printed on coated paper stock. Once in the machine, the bundle is squared from the sides, compressed from the top, strapped then quickly ejected from the strapping machine. Utilizing the quick change feature the machine can be adjusted to different publication sizes while the machine is in online.

### At A Glance

- **Servo Drive** eliminates clutches and brakes used in welding head control
- **Modern touch screen** display simplifies machine setup and improves operator troubleshooting
- **Automatic strap loading** and self strap cleaning after completion of coil
- **Operator station on both sides** of the machine to simplify machine operations
- **Variable speed conveyor** drive allows for better control of incoming bundles
- **Upstream and downstream interlocks** with complete plug connection
- **Unique bundle conditioning** system
- **All doors and covers can be either removed** or opened for fast access into the machine for service
- **Easily adjust bundle-stops** and bundle guides during machine operations
- **Bundle accelerator** and bounce back function
- **Signal light tower** for operation and error notification
- **Quick change coil dispenser** capable of using XL coils

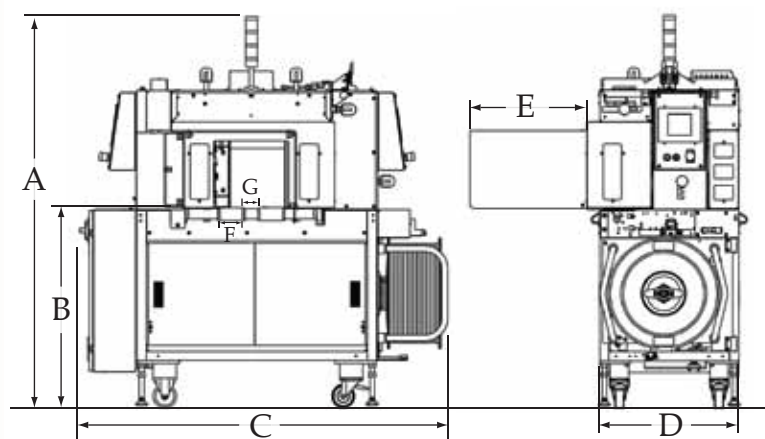

A	66.5" (1690mm)	E	19.9" (505mm)
B	34.0" (864mm)	F	3.9" (100mm)
C	62.5" (1588mm)	G	2.8" (72mm)
D	23.6" (600mm)		

### Specifications

<b>Overall Width:</b>	23.6" (600mm)
<b>Overall Length:</b>	62.5" (1588mm)
<b>Overall Height:</b>	66.5" (1690mm)
<b>Conveyor Height:</b>	34.0" (864mm)
<b>Strap Size:</b>	5mm or 6mm
<b>Single Strap Speed:</b>	55-60 Bundles min.
<b>Conveyor Speed:</b>	
<b>Feed Side:</b>	59 ft/m - 187 ft/m
<b>Discharge Side:</b>	78.7 ft/m - 206.7 ft/m
<b>Weight:</b>	1100 lbs (500 kg)
<b>Sealing Method:</b>	Heat Seal
<b>Operation:</b>	Electro-pneumatic
<b>Air Requirement:</b>	22.3 CFM @ 87 PSI
<b>Electrical Requirements:</b>	208V / 230V 440V / 460V 3 Phase Approximately 1.5 kW
<b>Bundle Size:</b>	5"-11" (127-279mm) 7"-15" (178 -381mm) .27"-9.8" (7mm-250mm)
<b>Bundle Weight:</b>	Max. 55.1 lbs (25 kg)



Certified Minority Owned Company

Phone: (800) 526-0827 | Fax: (757) 363-8016 | E-mail: [order@dynaric.com](mailto:order@dynaric.com) | Web: [www.dynaric.com](http://www.dynaric.com)