

MHB-2

The Dominator - Designed for the Hay Industry

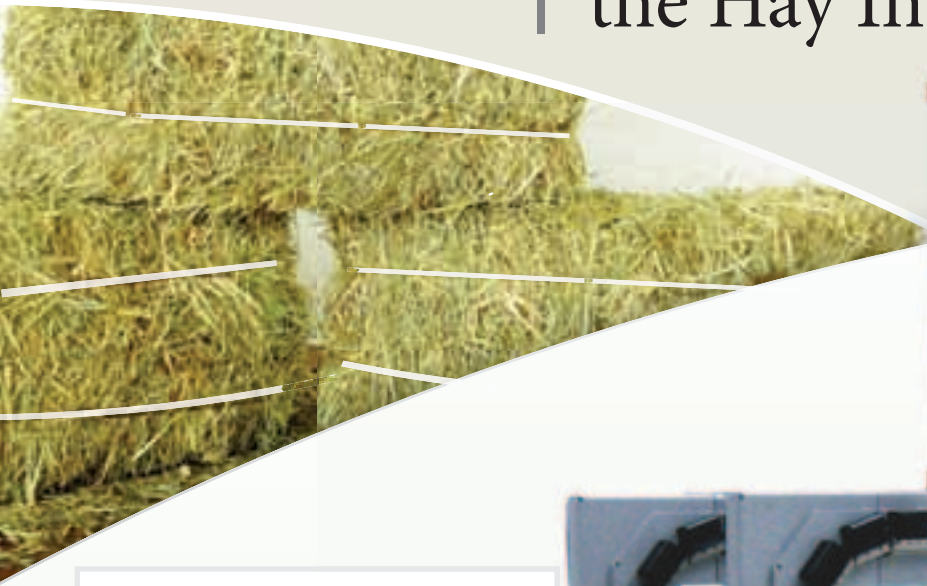

- ▶ Energy Efficient 24V Direct Drive Motors
- ▶ Fewer Moving Parts

Dynaric, Inc.





The MHB is a custom built side seal strapping machine designed to strap product vertically. The unique head location is designed to minimize foreign matter from interrupting machine performance. Designing a multiple head system can dramatically increase your production. Constructed with heavy-duty material and hardware allows this machine to operate flawlessly in virtually any environment.

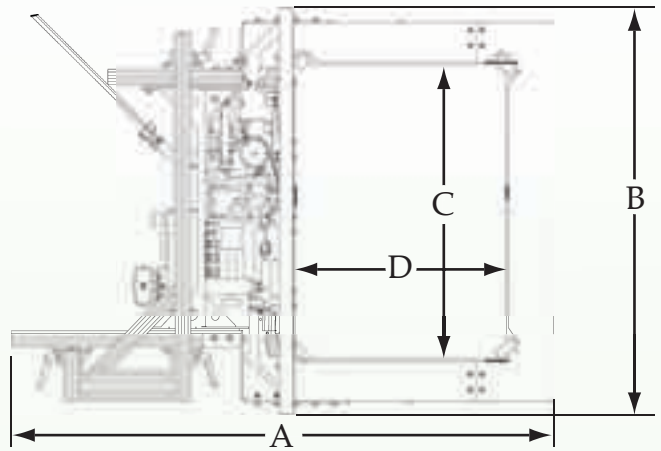

At A Glance

- Minimize downtime with our quick-change strapping unit
- Custom built to meet your needs
- Use Dynaric XXL coils to reduce downtime cause by coil changes
- Increased throughput instantly
- Automatic strap feed and refeed
- Debris protection
- Fewer moving parts to further increase reliability
- Direct drive motors means no belts or pulleys
- To ensure long-lasting operation the strapping and sealing unit are mounted vertically to avoid debris

A	55.6" (1414mm)
B	41.8" (1062mm)
C	30.6" (779mm)
D	21.6" (550mm)
E	27.9" (710mm)
F	14.2" (362mm)

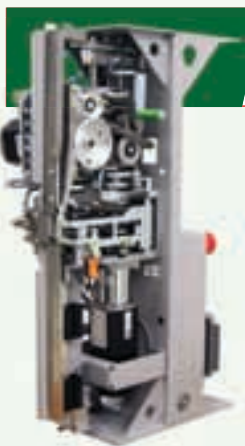

Quick Change Strapping Head

- Simplified maintenance
- By releasing two security clamps the head can be swapped out in minutes
- Less than 70 lbs
- Perform maintenance offline without the worry of production loss

Dynaric Advantage

Our superior plastic strapping and strapping equipment provide you with outstanding reliability in-turn reducing machine downtime.

Our factory trained technicians will take the time necessary to train your personal after the machine installation is completed.

We have 24 hours technical support to quickly diagnose the problem to get you back up and running again.

Dynaric, Inc.

