

CP Series

Strapping Machines and System

THE DOWNTIME ELIMINATORS

CP-1 The CP-1 is the lead machine in the CP series of commercial printing strapping systems. The CP-1 is designed to stabilize the bundles of printed matter, especially hard to handle magazines printed on coated paper stock. The CP-1 machine has a close-coupled design that insures smooth transfer of the bundle between the stacker and the strapper. Once in the machine, the bundle is squared from the sides, compressed from the top, strapped and then ejected to be cross-strapped or wrapped. The CP-1 has a quick-change feature that allows the machine to be adjusted to a different publication size in a matter of seconds.



CP-2 The CP-2 is the second machine in the CP series commercial printing strapping system. It is designed to be used as the cross strap machine in conjunction with the CP-1. The bundle can be oriented for cross strapping by use of a Dynaric bump table or by the use of a 90-degree right angle conveyor transfer. The CP-2 is also used in several applications as the first position strapper. Since the CP-2 is equipped with a conveyor belt table top to efficiently discharge the cross bundle from the system, it is ideal to marry with stackers that do not push fully into the strapper.



Dynaric, Inc.



®

CP Series

Strapping Machines and System

FEATURES AND BENEFITS

- ◆ High speed – 40 bundles per minute
- ◆ Programmable Logic Control
- ◆ Automatic Strap Feeding
- ◆ Digital Diagnostic display for trouble shooting
- ◆ Bundle conditioning system – air operated
- ◆ Calibrated bundle guides and stops for quick adjustment
- ◆ Warning light system
- ◆ Swing arm command control panel
- ◆ External tension adjustment
- ◆ Hinged conveyor tops and (3) access panels
- ◆ Foam covered clamp for product protection
- ◆ Mechanically actuated, segmented track
- ◆ Removable dispenser – simplifies coil change

CP-1 / CP-2

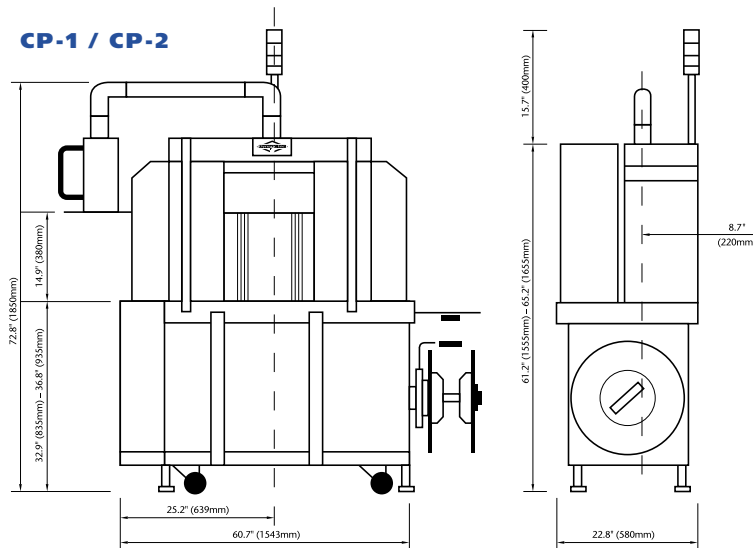

CP SERIES CROSS STRAPPING SYSTEM

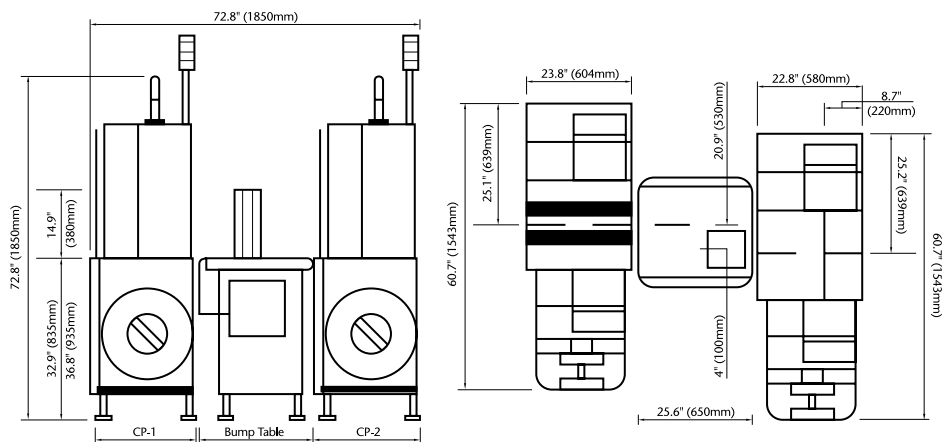

OPTIONS FOR CP-1 / CP-2

Spare Dispenser:

Reduces time required for coil change

Air Gun w/ Spiral Hose:

Facilitates cleaning

End of Strap Sensor:

Signals when coil is running low

SPECIFICATIONS

Capacity:	40 bundles per minute
Power Supply:	230V or 460V 3 phase, 60 Hz.
Strap Size:	5.8mm
Weight:	1100 lbs.
Seal Joint:	Weld Length 1"

Sealing Method:	Heat Seal
Air Requirement:	24 CFM @ 90PSI
Max. Bundle Size:	8.6"W x 12.2"L x 14.1"H
Min. Bundle Size:	5.2"W x 7.9"L x .4"H

Dynaric, Inc.



Glenpointe Centre West, 500 Frank W. Burr Blvd., Teaneck, NJ 07666
 800-526-0827 201-692-7700 Fax: 201-692-7757 E-mail: gd@dynaric.com