

Dynaric, Inc.

MHB Strapping Head

The **NEW**
CLASS for
Automatic
Strapping
Machines

Designed to exceed
your packaging
needs and lower
your overall cost of
manufacturing.

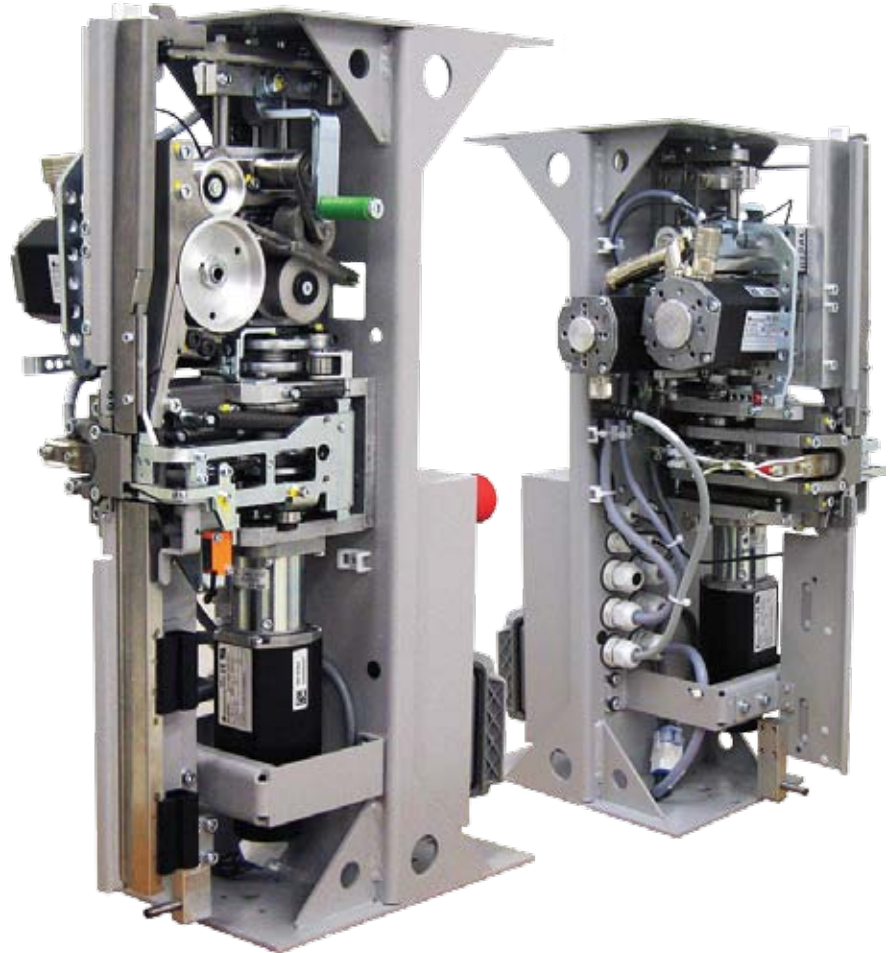

BENEFITS:

- User-friendly and intuitive
- Economical due to high availability
- Robust and extremely low maintenance
- Powerful
- Variable strap width

EQUIPMENT:

- Tension adjustable with 10 steps
- Operation Terminal with Soft-Button
- DAT “Direct-Access-Technology”
- ASLF “Anti-Strap-Loss-Function” Constant strap control
- Wear-free Strap frame by stainless steel guide
- Wear-free, energy saving direct-drive motors
- Adjustable torque controlled strap tension
- Automatic Strap feed

Dynaric, Inc.



MHB Strapping Head

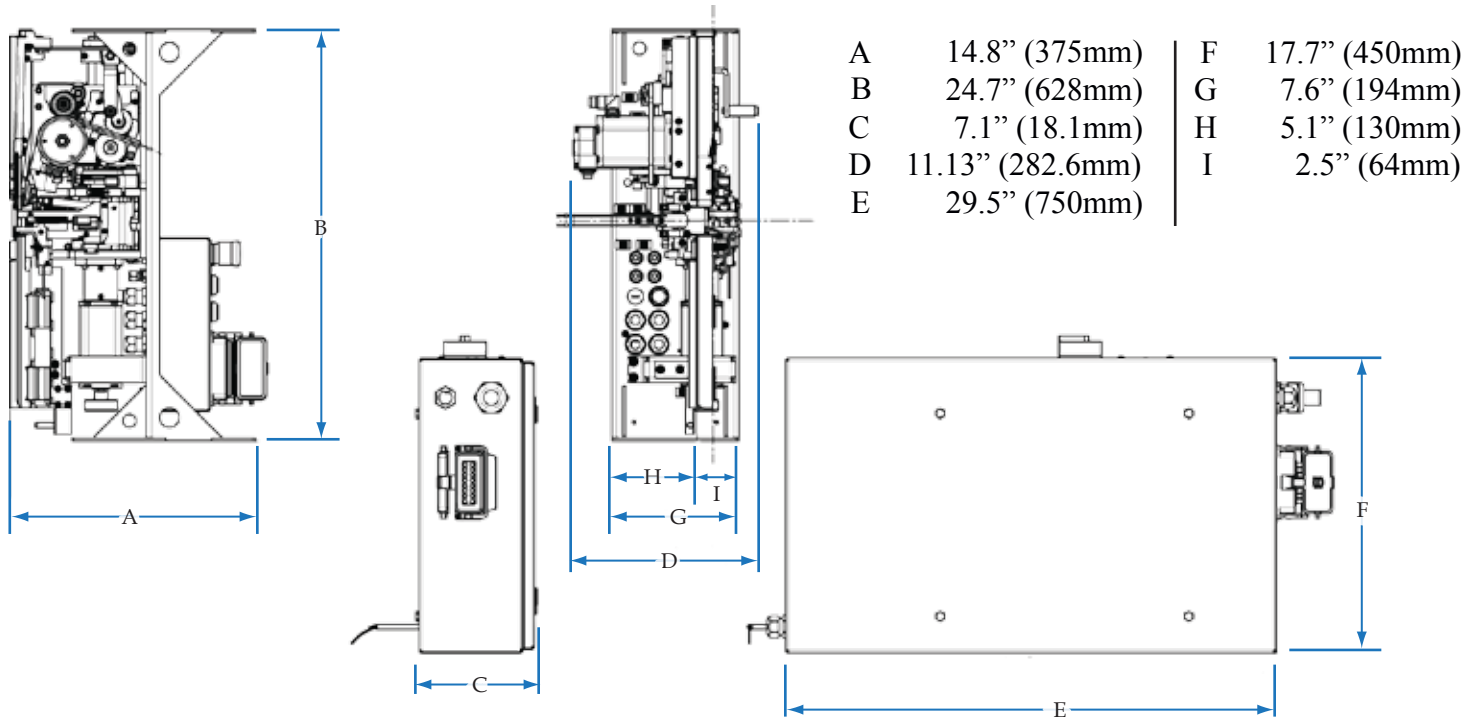

TECHNICAL SPECIFICATION

CAPACITY

Based on bundle size of 500mm x 500mm.

Single strap up to 50 bundles/min.
Depending on arch size and tension force

BUNDLES

Width: Min. 55mm
Max. Depending on arch size
Height: Min. 80mm
Max. Depending on arch size

STRAP TENSION

Adjustable with 10 steps
Strap tension: Max. 380N

STRAPPING MATERIAL

Polypropylene: Width 12-15mm
Thickness 0.4-0.9mm

SEALING METHOD

Tensile strength of welded joint is approx. 60 - 80% of the breaking strength of the strap
Heat seal

POWER SUPPLY

Wide Range Input: 1-Phase 90 - 264 Volts AC; 47 - 63 Hz
3-Phase 340 - 575 Volts AC; 47 - 63 Hz
Maximum Fusing: 16A (B-character)
Protection Type: IP 22

POWER CONSUMPTION

Total Consumption: approx. 0.5 kw

WEIGHT

Total Weight: approx. 154 lbs. (70 kg)

OPERATING CONDITIONS

Temperature Range: 32 - 122F (0 - 50C)



Corporate Office
5740 Bayside Road
Virginia Beach, VA 23455

Extrusion Division
5925 Thurston Ave
Virginia Beach, VA 23455

Certified Minority Owned Business