

**Dynaric, Inc.**



®

# CP100

## Downtime Eliminator

### High Speed Strapping Machine

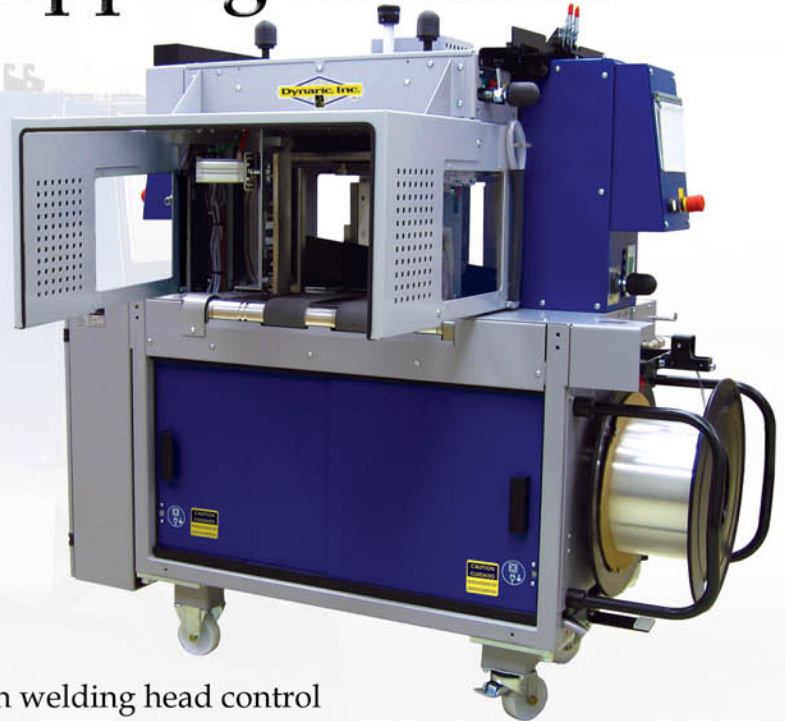

#### Features & Benefits

- ◆ Servo Drive eliminates clutches and brakes used in welding head control
- ◆ Modern touch screen display simplifies machine setup and improves operator troubleshooting
- ◆ Automatic strap loading and self strap cleaning after completion of coil
- ◆ Operator station on both sides of the machine to simplify machine operations
- ◆ Variable speed conveyor drive allows for better control of incoming bundles
- ◆ Upstream and downstream interlocks with complete plug connection
- ◆ Unique bundle conditioning system
- ◆ All doors and covers can be either removed or opened for fast access into the machine for service
- ◆ Easily adjust bundle-stops and bundle guides during machine operations
- ◆ Bundle accelerator and bounce back function
- ◆ Signal light tower for operation and error notification
- ◆ Quick change coil dispenser capable of using XL coils

5740 Bayside Road, Virginia Beach, VA 23455

Phone: (800) 526-0827 Fax: (757) 363-8016 E-mail: [order@dynaric.com](mailto:order@dynaric.com) Web address: [www.dynaric.com](http://www.dynaric.com)

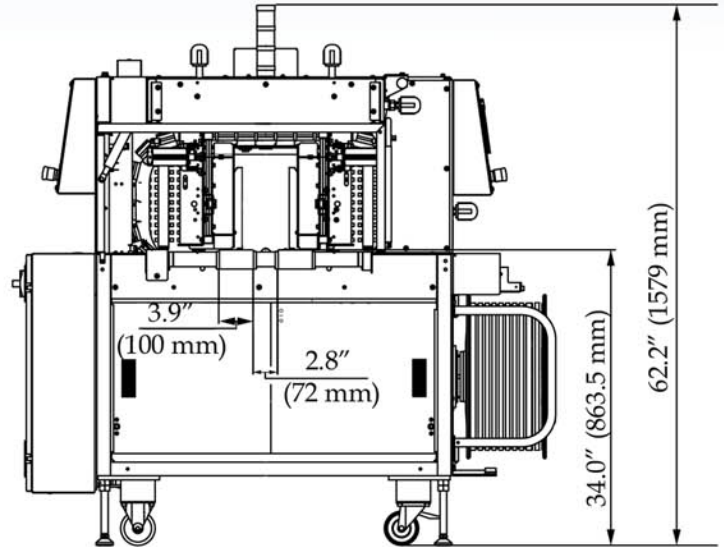
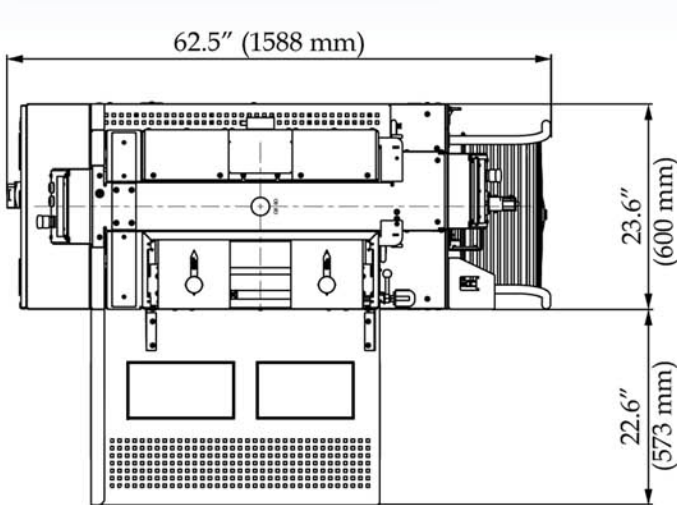

## Specifications

Overall Width:	23.6" (600 mm)
Overall Length:	62.5" (1588 mm)
Overall Height:	62.2" (1579 mm)
Conveyor Height:	34.0" (863 mm)
Strap Size:	5mm or 6mm
Speed:	
Single Strap	48-52 Bundles.min
Conveyor Speed:	
Feed Side	59 ft/m - 187 ft/m
Discharge Side	78.7 ft/m - 206.7 ft/m

Weight:	1100 lbs (500 kg)
Sealing Method:	Heat Seal
Operation:	Electro-pneumatic
Air Requirement:	22.3 CFM @ 87 PSI
Electrical Requirements:	208V / 230V 440V/460V 3 Phase Approximately 1.5 kW
Bundle Size:	
Width	5"-11" (127 mm-279 mm)
Length	7"-15" (178 mm-381 mm)
Height	.27"-9.8" (7mm-250mm)
Weight	55.1 lbs (25 kg)