

Dynaric, inc.

DF-118BAL

Automatic Side Seal Strapping Machine

Designed to
Exceed the
Demanding
Requirements
of the Hay
Baling Industry



Ultraband

The DF118BAL can be setup to use Dynaric's Ultraband strapping. Ultraband is a heavy-duty low elongation polypropylene strap designed to give you the same strength and durability as PET or Steel strapping without the cost.

Dynaric, Inc.



Phone: (800) 526-0827 Fax: (757) 363-8016 - E-mail: gd@dynaric.com - Web address: www.dynaric.com

Dynaric, inc.

DF-118BAL

The DF-118BAL has been custom designed for the hay baling industry.

It is available on new press equipment and can also be retrofit into existing presses right at your location. Working in conjunction with the major press manufacturers the DF-118BAL provides a very reliable and fast strapping designed with a breakaway arch in sizes to match today as well as tomorrows bale sizes. The breakaway arch allows for the machine to be moved into and out of line quickly and easily. The DF-118BAL requires 3 phase power and can be ordered to run 12mm (1/2) or 15mm (5/8") strap. To minimizing required floor space the dispenser is externally located and top mounted. The sealing head is located on the side so that the amount of dust and debris reaching it is minimized. The strapping material is heat sealed for maximum seal efficiency.

Features

- Compatible with most hay press manufacturers
- Sealing head located above area where falling dust and chaff occur
- Utilizes few moving parts
- Fastest cycle time
- Detachable arch for easy maintenance
- Easy strap feeding
- Uses polypropylene strapping on standard or XL coils
- Adjustable external tension control
- Short feed indicator
- Re-feed function
- Anti-jamming feature
- Self diagnostic capabilities
- Adjustable heater temperature, seal time, feed time and tensioning timer control

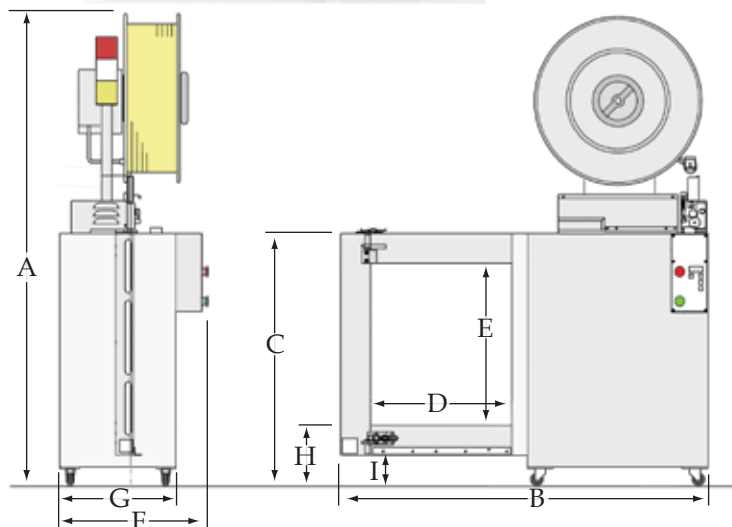

A	80.3" (2040mm)	F	20.1" (510mm)
B	56.1" (1425mm)	G	17.7" (450mm)
C	38.3" (974mm)	H	9.2" (234mm)
D	21.6" (550mm)	I	4.6" (419mm)
E	24.6" (625mm)		

Overall Width:	20.1" (510 mm)
Overall Length:	56.1" (1425 mm)
Overall Height:	80.3" (2040 mm)
Machine Weight:	685 lbs. (310.7 kg)
Sealing Method:	Heat Seal
Seal Head Location:	Side - 24.6" from floor
Arch Size:	Height: 24.6" (625 mm) Width: 21.6" (550 mm)
Cycle Time:	1.4 seconds
Cycle Initiation:	Push Button
Tension:	11-260 lbs.(48.9-1156.5 N)
Minimum Bundle Size:	2.0"H X 4"W
Maximum Bundle Size:	24"H X 21"W
Power Supply:	220 volt, 3 phase, 60Hz 440 volt, 3 phase, 60Hz. (optional)
Mobility:	2.9" "V" Grooved casters
Strap Size:	12 mm and 15.5 mm Low elongation strap
Dispenser:	16" I.D./8" Face/24" O.D. externally located, top mounted

Dynaric, Inc.



Phone: (800) 526-0827 Fax: (757) 363-8016 - E-mail: gd@dynaric.com - Web address: www.dynaric.com