

Dynaric DF11SA

Stainless Steel Fully Automatic Bottom Seal Strapping Machine

Designed for
the Harsh
Packaging
Environments
of the **Meat,**
Poultry and
Seafood
Industries



Cost Reduction, Labor Saving



5740 Bayside Road, Virginia Beach, VA 23455

Phone: (800) 526-0827 Fax: (757) 363-8016

E-mail: gd@dynaric.com

Web address: www.dynaric.com

Dynaric DF11SA

- Anti-jam feature eliminates strap jams in unit
- Internal dispenser; minimizes required floor space, keeps strap dry
- Available in 220 volts, 3-phase or 440 volt, 3-phase (optional)
- Electronic control pads allows the operator to easily adjust timer functions, heater temperature setting and seal time
- Digital display reflects the unit's operational status, including an error read-out for easy troubleshooting
- Easy strap feeding and adjustable external tension control and heat seal allows operators to strap packages in easy, efficient manner
- Adjustable photo eyes allows you to automatically strap virtually any package size
- Energy saving feature; motor automatically shuts down when machine is not in use
- Heavy-Duty casters allow for the machine to be easily moved throughout your facility
- Available for use with 3/8" or 1/2" strapping

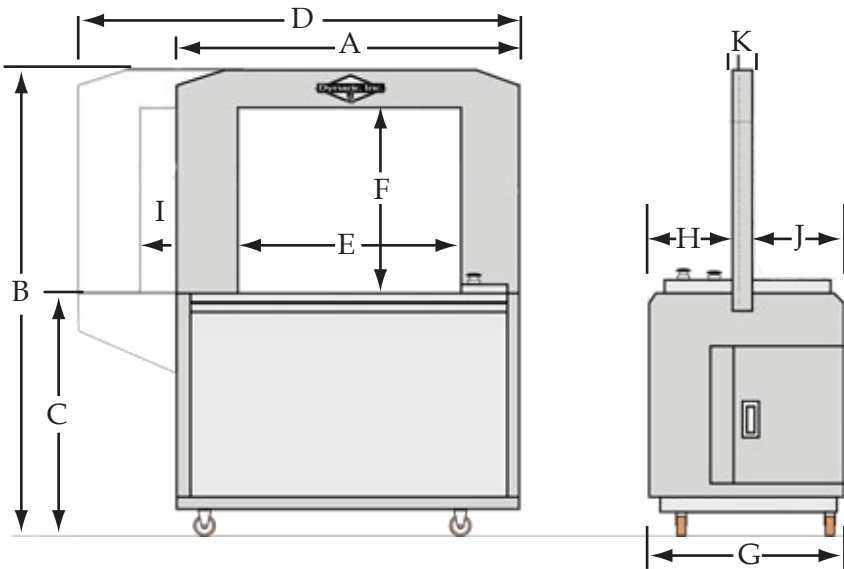

A	44.7" (1135mm)
B	60.8" (1545mm)
C	31.3" (795mm)
D	52.5" (1335mm)
E	27.6" (700mm)
F	23.6" (600mm)
G	25.6" (650mm)
H	11.6" (295mm)
I	35.4" (900mm)
J	14.0" (355mm)
K	2.8" (71mm)

Overall Width:	25.6" (650 mm)
Overall Length:	44.7" (1135 mm)
Overall Height:	60.8" (1544 mm)
Table Height:	31.3" (795mm)
Weight:	506 lbs (230 kg)
Cycle Time:	1.6 seconds
Cycle Initiation:	Foot Switch, Push Button or Photo Eyes
Strap Size:	3/8" & 1/2" (9mm & 12mm)

Package Size:	Min. 1.2" H x 1.6" W Max. Governed By Arch
Tension:	Internally located, adjustable 10 - 250 lbs.
Seal Head Location:	Bottom
Sealing Method:	Heat Seal
Mobility:	2 swivel and 2 fixed casters
Dispenser:	Internally located - 9" I.D./8" Face/18" O.D.
Power:	220V, 3 phase, 60Hz 440V, 3 phase, 60Hz



5740 Bayside Road, Virginia Beach, VA 23455
 Phone: (800) 526-0827 Fax: (757) 363-8016
 E-mail: gd@dynaric.com
 Web address: www.dynaric.com