

DF30L

Semi-Automatic Low Table Strapping Machine



The DF-30L is an economical, easy to use strapping machine.

Equipped with externally adjustable strap feed and electronic tension control, the DF-30L is the perfect strapper for securing and unitizing outgoing shipments of heavy oversized product. An audible cycle alert safety signal, "ACASS," is given when the strap has been inserted into the sealing mechanism prior to tensioning. This signal offers added safety for the operator.

Give your back a break! Use the DF30L - eliminate the stress on your back caused by handling heavy packages on standard height strapping machines.

Features

- Utilizes a direct drive dual motor system, eliminating the need for clutches and brakes
- Improved strap feed system eliminates slipping during tensioning even under the harshest conditions
- Suited to handle all office and industrial packaging applications
- New, state-of-the-art innovative design with rounded corners for personal protection
- Compact, lightweight assembly, for easy mobility throughout your facility
- Compact, low maintenance sealer head
- 5mm - 15mm strapping can be used
- Audible cycle alert safety signal (ACASS) system
- Cycle time capable of 25 - 30 straps per minute
- Strap feed and tension are externally controlled
- Minimal maintenance and lubrication required
- Easily accessible strap dispenser
- Dispenser braking system with no belts to wear or adjust
- Complete accessibility for maintenance
- Operates on 120 volt single phase power



5740 Bayside Road, Virginia Beach, VA 23455
Phone: (800) 526-0827 Fax: (757) 363-8016
E-mail: gd@dynaric.com
Web address: www.dynaric.com

DF30L

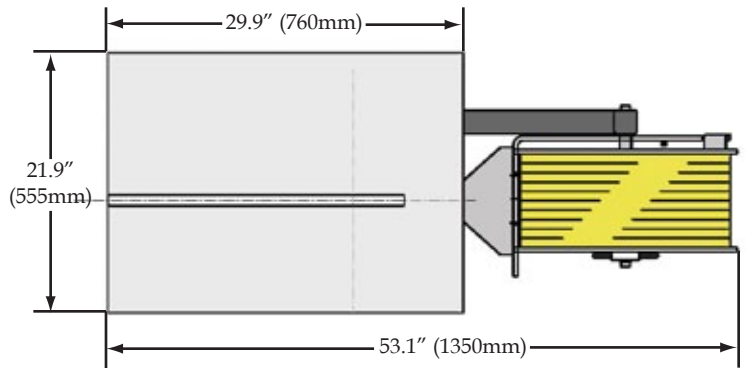
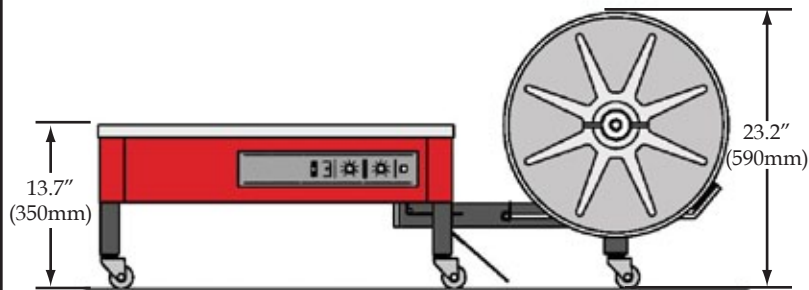

Specifications

Overall Width:	21.9" (555mm)	Min. Package Size:	4" (102mm)x2.4" (61mm) (HxW)
Overall Length:	53.1" (1350mm)	Max. Package Wt.:	180 lbs. (81.6 kgs.)
Overall Height:	23.2" (590mm)	Mobility:	(5) Casters, two of which are locking
Table Height:	13.7" (350mm)	Strapping Size:	1/4" to 5/8" (5mm to 15mm) a simple guide change and adjustment is required*
Machine Weight:	143 lbs. (64.8 kgs.)	Table Size:	29.9" (760mm) x 21.9" (555mm) (LxW)
Sealing Method:	Heat Seal	Dispenser:	9" (229mm) 1.0 / 8" (230mm) Face /18" (457mm) O.D.* 8" (203mm) 1.0 / 8" (203mm) Face /18" (203mm) O.D.*
Seal Head Location:	Bottom: 9.25" (240mm) in from the right hand edge		
Power Supply:	115 volt, single phase		
Cycle Time:	2.0 seconds		
Cycle Initiation:	Strap insertion with "ACASS" System		
Tension:	External: Electronic Adjustable Control: 6-120 lbs.		

* Must be specified when ordering



5740 Bayside Road, Virginia Beach, VA 23455
Phone: (800) 526-0827 Fax: (757) 363-8016
E-mail: gd@dynaric.com
Web address: www.dynaric.com