

Dynaric, Inc.

NP5000X

High Speed Fully Automatic Cross Strapping Machine



Touch screen display
simplifies machine setup



XL Coils

Increase your production further by reducing downtime caused by changing coils. Dynaric's XL coils are still produced using the same high quality materials as our standard coils but with more footage therefore eliminating up to 30% of your coil changes.

Dynaric, Inc.



®

Phone: (800) 526-0827 Fax: (757) 363-8016 E-mail: gd@dynaric.com Web address: www.dynaric.com

Dynaric, Inc.

NP5000X



The NP5000X is the latest addition to the Dynaric line of dependable newspaper strapping machines. The state of the art AC Servo Drive enables throughputs of 20 crossed strapped bundles per minute. The operator interface is enhanced through the use of a touch screen while maintenance is simplified by the use of fewer moving parts.

Features and Benefits

- AC Servo Drive eliminates clutches and brakes used in welding head control
- Modern touch screen display simplifies machine setup and improves operator troubleshooting
- Automatic strap tensioning depending on height of bundle improves product consistency
- Automatic strap loading and self strap clearing after completion of coil speeds up coil changes
- Operator stations on both sides of machine simplify operation
- Bundle stops and side squaring bars preserve bundle integrity
- Simplified strap arch with fewer moving parts improves long term reliability
- Quick-change strap dispenser with capacity for Extra Length (Dynaric XL) coils extends time between coil changes.
- Soft bundle press conforms to odd shaped bundles for more consistent tension
- Variable speed conveyor drive allows speed matching for better control of incoming bundles

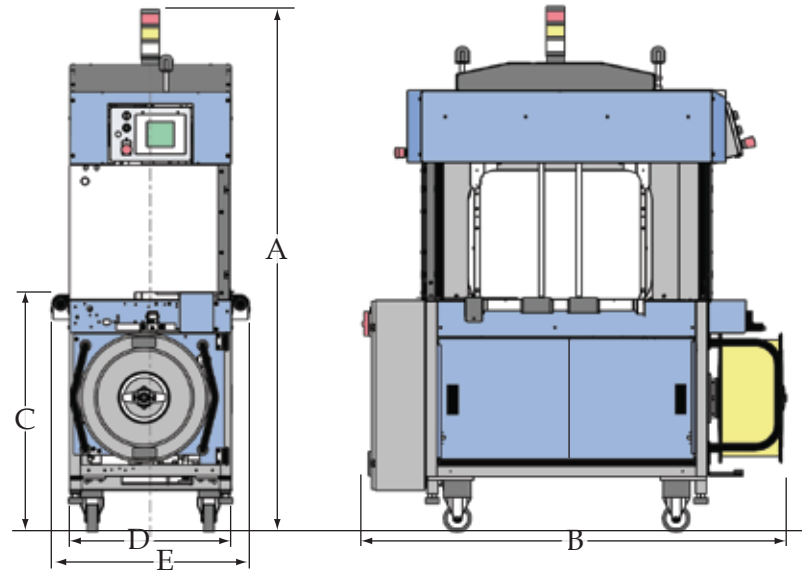

A	70.9-76.0" (1800-1930mm)	D	23.8" (604mm)
B	61.4" (1559mm)	E	29.0" (736mm)
C	31.5-36.6" (800-930mm)		

Overall Width:	29.0" (736 mm)
Overall Length:	61.4" (1559 mm)
Overall Height:	70.9" - 76.0" (1800 - 1930 mm)
Conveyor Height:	31.5" - 36.6" (800 - 930 mm)*
Strap Size:	6 mm (5 mm optional)*
Speed:	cross straps: 20 Bundles/ min
	parallel straps: 25 Bundles/ min
	single strap: 45 Bundles/ min
	50 straps/ min

Weight:	1190 lbs (540 kg)
Sealing Method:	Heat Seal
Operation:	Electro-pneumatic
Air Requirement:	22.3 CFM @ 87 PSI
Electrical Requirements:	Approximately 1.5 kW
Bundle Size:	Width: Max. 22" (560 mm)
	Min. 7.9" (200 mm)
	Length: Min. 6.7" (170 mm)
	Height: Max. 15.7" (400 mm)
	Min. 0.4" (10 mm)
	Weight: Max. 55.11bs (25 kg)

*Specify with order

