

Dynaric, Inc.
D2400

High Speed Automatic Strapping Machine

Innovative,
Reliable,
"Jam-Free"
Operation



XL
Coils

Increase your production further by reducing downtime caused by changing coils. Dynaric's XL coils are still produced using the same high quality materials as our standard coils but with more footage therefore eliminating up to 30% of your coil changes.

Dynaric, Inc.



Phone: (800) 526-0827 Fax: (757) 363-8016 E-mail: gd@dynaric.com Web: www.dynaric.com

Think Before You Click Print!

Dynaric, Inc.

D2400

Features

- New state of the art digital display includes a "0" tension button for sensitive bundles and up / down arrow keys for simple tension adjustment.
- Ejector finger, located in welding head, allows for runs where extremely low levels of tension are required, automatically detecting and correcting strap problems; and ensuring- reliable, jam-free operations.
- High speed cycle time, capable of more than 50 cycles per minute.
- Optional auto-bundle sensor, senses height and adjusts tension within range.
- Easy-strap feeding, strap is inserted into the feeding slot and the machine automatically feeds itself.
- Equipped with safety strap cutters outside the machine; no knives or scissors are necessary to cut the strap.
- Automatic mechanism removes any leftover strap when strap coil is finished.
- External dispenser allows you to determine when strap is low. The external location, coupled with adjustable machine height, allows for convenient and safe coil changes.
- Strap cycle can be initiated by photo eye switch or foot bar.
- The machine table height can be adjusted up or down, from 29.5" to 35.4", to accommodate your requirements.
- Durable machine with reinforced arch and thick plates holds up to demanding environments.
- Four 3" swivel casters allow for easy mobility.
- Accepts 5mm, 6mm or 9mm strapping, requiring no additional parts or costs to change the strap size.
- Runs on 110V single phase.

Strapping Everything

from Containers
and Lumber to
Mail Trays
and Doors



Dynaric, Inc.



Phone: (800) 526-0827 Fax: (757) 363-8016 E-mail: gd@dynaric.com Web: www.dynaric.com

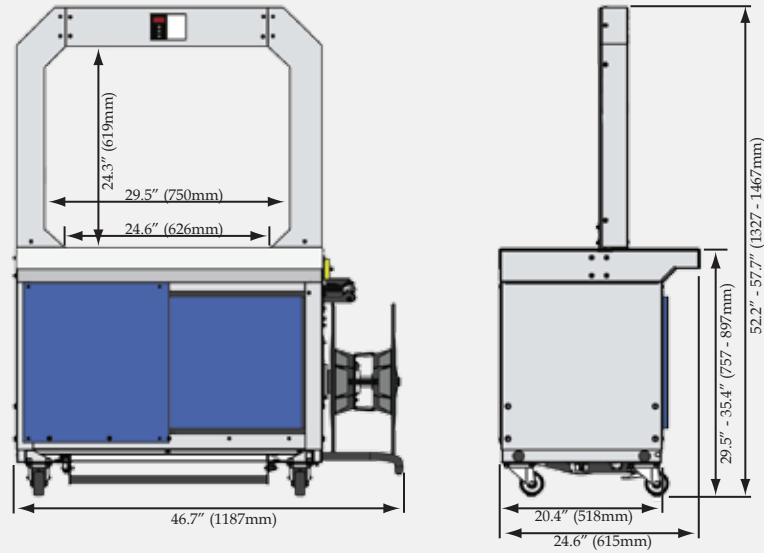

Custom arch sizes are available

Overall Width:	24.6" (615mm)
Overall Length:	46.7" - 72.5" (1187 - 1844mm)*
Overall Height:	58.6" - 64.5" (1327 - 1642mm)*
Table Height:	29.5" - 35.4" (757 - 897mm)
Weight:	375 lbs. - 540 lbs. (170 - 245kg.)*
Cycle Time:	1.1 seconds*
Cycle Initiation:	Photo eye sensor or Foot bar
Strap Size:	1/4" & 3/8" (5mm - 9mm)
Package Size:	Max. Governed By Arch Min. 1.5" H x 3" W
Tension:	Adjustable electronic control
Seal Head Location:	Bottom
Sealing Method:	Heat Seal
Mobility:	3" Casters
Dispenser:	Externally located- 8" or 9" I.D./8" Face/18" O.D
Power:	110 Volt Single Phase

*Depending on Arch Size